



CITY OF STAMFORD, CONNECTICUT  
 OFFICE OF BUILDING INSPECTOR  
 APPLICATION FOR SIGN PERMIT

(Permit must be obtained before beginning work)

Stamford, Conn. \_\_\_\_\_, 20\_\_\_\_\_

TO THE BUILDING INSPECTOR:

Applicant \_\_\_\_\_ hereby applies

for permission to erect GROUND  FRONT  SIDE  REAR   
 The same to be in all respects in accordance with laws and building regulations of the City of Stamford and the State of Connecticut, and as set forth in the accompanying drawings and specifications in so far as the same shall be found not to conflict with the aforesaid State and City Laws and Building Regulations.

Located on N S E W side of street \_\_\_\_\_  
 Number \_\_\_\_\_ Street \_\_\_\_\_

Owner of Land \_\_\_\_\_ Address \_\_\_\_\_

Owner of Building \_\_\_\_\_ Address \_\_\_\_\_

Tenant \_\_\_\_\_ Address \_\_\_\_\_

Dimensions or sign \_\_\_\_\_ No. of square feet \_\_\_\_\_

Sign Cost \_\_\_\_\_ Fee \_\_\_\_\_

How fastened \_\_\_\_\_ Electric: yes or no \_\_\_\_\_

Height from ground for pole sign \_\_\_\_\_

Material used for sign \_\_\_\_\_

Sign erector's name \_\_\_\_\_ Address \_\_\_\_\_

Electrician \_\_\_\_\_ Address \_\_\_\_\_

Distance back from lot line \_\_\_\_\_

Draw a plot plan on back of application and show distance back from front and side property lines; also, show how far back the building is for a sign on building.

\_\_\_\_\_  
 Signature of Tenant

\_\_\_\_\_  
 Signature of Building or Lot Owner

\_\_\_\_\_  
 Address

\_\_\_\_\_  
 Address

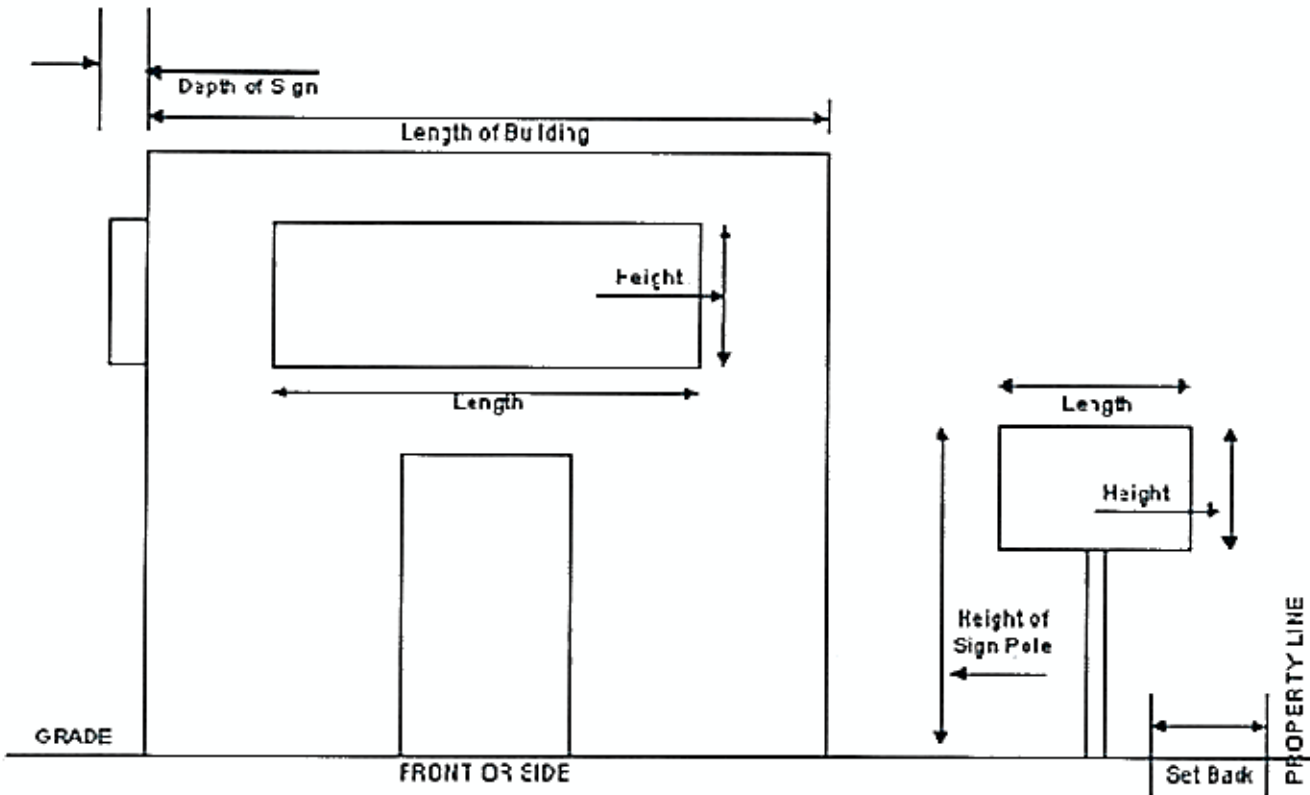

SIGN PERMIT NO. \_\_\_\_\_

FEE \_\_\_\_\_ .00 \_\_\_\_\_

COST \_\_\_\_\_ .00 \_\_\_\_\_

DATE \_\_\_\_\_

Location \_\_\_\_\_

Owner \_\_\_\_\_

Address \_\_\_\_\_

Tenant \_\_\_\_\_

Address \_\_\_\_\_

Sign Erector \_\_\_\_\_

Applicant \_\_\_\_\_

Code Official \_\_\_\_\_